



TEST REPORT

Test Report No. : UL-RPT-RP13337971-1216A V3.0

Customer : Raspberry Pi (Trading) Ltd
Model No. / PMN : Raspberry Pi RM0
HVIN : Raspberry Pi RM0
FCC ID : 2ABCB-RPIRM0
ISED Certification No. : IC: 20953-RPIRM0
Technology : *Bluetooth* – Low Energy
Test Standard(s) : FCC Parts 15.247(a)(2), 15.247(e), 15.247(b)(3) & 15.247(d)
Innovation, Science and Economic Development Canada
RSS-247 Issue 2 Sections 5.2(a), 5.2(b) & 5.4(d) & 5.5
RSS-Gen Issue 5 Sections 6.7, 6.12 & 8.2
Test Laboratory : UL International (UK) Ltd, Basingstoke, Hampshire, RG24 8AH,
United Kingdom

1. This test report shall not be reproduced except in full, without the written approval of UL International (UK) Ltd.
2. The results in this report apply only to the sample(s) tested.
3. The sample tested is in compliance with the above standard(s).
4. The test results in this report are traceable to the national or international standards.
5. Version 3.0 supersedes all previous versions.

Date of Issue: 05 November 2020

Checked by: 
Sarah Williams
RF Operations Leader, Radio Laboratory

Company Signatory: 
Ben Mercer
Lead Project Engineer, Radio Laboratory



5772

The *Bluetooth*® word mark and logos are owned by the *Bluetooth* SIG, Inc. and any use of such marks by UL International (UK) Ltd is under licence. Other trademarks and trade names are those of their respective owners.

UL International (UK) Ltd

Unit 1-3 Horizon, Kingsland Business Park, Wade Road, Basingstoke, Hampshire, RG24 8AH, UK
Telephone: +44 (0)1256 312000
Facsimile: +44 (0)1256 312001

Customer Information

| | |
|----------------------|--|
| Company Name: | Raspberry Pi (Trading) Ltd |
| Address: | Maurice Wilkes Building Cowley Road Cambridge CB4 0DS United Kingdom |

Report Revision History

| Version Number | Issue Date | Revision Details | Revised By |
|-----------------------|-------------------|-------------------------------|-------------------|
| 1.0 | 20/10/2020 | Initial Version | Sarah Williams |
| 2.0 | 30/10/2020 | Lower Band Edge results added | Ben Mercer |
| 3.0 | 05/11/2020 | PMN/HVIN updated | Sarah Williams |

Table of Contents

Customer Information..... 2

Report Revision History 2

Table of Contents..... 3

1. Attestation of Test Results..... 4

 1.1. Description of EUT 4

 1.2. General Information 4

 1.3. Summary of Test Results 5

 1.4. Deviations from the Test Specification 5

2. Summary of Testing..... 6

 2.1. Facilities and Accreditation 6

 2.2. Methods and Procedures 6

 2.3. Calibration and Uncertainty 7

 2.4. Test and Measurement Equipment 8

3. Equipment Under Test (EUT) 9

 3.1. Identification of Equipment Under Test (EUT) 9

 3.2. Modifications Incorporated in the EUT 9

 3.3. Additional Information Related to Testing 9

 3.4. Description of Available Antennas 9

 3.5. Description of Test Setup 10

4. Antenna Port Test Results 14

 4.1. Transmitter Duty Cycle 14

 4.2. Transmitter 99% Occupied Bandwidth 15

 4.3. Transmitter Minimum 6 dB Bandwidth 17

 4.4. Transmitter Maximum Peak Output Power 19

 4.5. Transmitter Band Edge Conducted Emissions 21

1. Attestation of Test Results





1.1. Description of EUT

The equipment under test was a *Bluetooth* and WiFi radio module.

1.2. General Information

| | |
|---------------------------------|---|
| Specification Reference: | 47CFR15.247 |
| Specification Title: | Code of Federal Regulations Volume 47 (Telecommunications): Part 15 Subpart C (Intentional Radiators) - Section 15.247 |
| Specification Reference: | 47CFR15.209 |
| Specification Title: | Code of Federal Regulations Volume 47 (Telecommunications): Part 15 Subpart C (Intentional Radiators) - Section 15.209 |
| Specification Reference: | RSS-Gen Issue 5 March 2019 |
| Specification Title: | General Requirements for Compliance of Radio Apparatus |
| Specification Reference: | RSS-247 Issue 2 February 2017 |
| Specification Title: | Digital Transmission Systems (DTSs), Frequency Hopping Systems (FHSs) and Licence-Exempt Local Area Network (LE-LAN) Devices |
| Site Registration: | FCC: 621311, ISEDC: 20903 |
| Location of Testing: | Unit 3 Horizon, Wade Road, Kingsland Business Park, Basingstoke, Hampshire, RG24 8AH, United Kingdom |
| Test Dates: | 28 July 2020 to 28 October 2020 |

1.3. Summary of Test Results

| FCC Reference (47CFR) | ISED Canada Reference | Measurement | Result |
|------------------------------|-------------------------------|---|---|
| Part 15.35(c) | RSS-Gen 8.2 | Transmitter Duty Cycle | Note 1 |
| N/A | RSS-Gen 6.7 | Transmitter 99% Occupied Bandwidth |  |
| Part 15.247(a)(2) | RSS-Gen 6.7 / RSS-247 5.2(a) | Transmitter Minimum 6 dB Bandwidth |  |
| Part 15.247(b)(3) | RSS-Gen 6.12 / RSS-247 5.4(d) | Transmitter Maximum Peak Output Power |  |
| Part 15.247(e) | RSS-247 5.2(b) | Transmitter Power Spectral Density | Note 2 |
| Part 15.247(d) & 15.209(a) | RSS-Gen 6.13 / RSS-247 5.5 | Transmitter Band Edge conducted Emissions |  |

Key to Results

 = Complied  = Did not comply

Note(s):

1. The measurement was performed to assist in the calculation of the level of the emissions. The EUT cannot transmit continuously and sweep triggering/signal gating cannot be implemented.
2. In accordance with ANSI C63.10 Section 11.10.1, PSD measurements are not required if the maximum conducted output power is less than the PSD limit of 8 dBm / 3 kHz. The PSD level is therefore deemed to be equal to the measured output power.

1.4. Deviations from the Test Specification

For the measurements contained within this test report, there were no deviations from, additions to, or exclusions from the test specification identified above.

2. Summary of Testing

2.1. Facilities and Accreditation

The test site and measurement facilities used to collect data are located at Unit 3 Horizon, Wade Road, Kingsland Business Park, Basingstoke, Hampshire, RG24 8AH, United Kingdom.

UL International (UK) Ltd is accredited by UKAS. The tests reported herein have been performed in accordance with its terms of accreditation.

2.2. Methods and Procedures

| | |
|-------------------|--|
| Reference: | ANSI C63.10-2013 |
| Title: | American National Standard of Procedures for Compliance Testing of Unlicensed Wireless Devices |
| Reference: | KDB 558074 D01 15.247 Meas Guidance v05r02, April 2, 2019 |
| Title: | Guidance for Compliance Measurements on Digital Transmission System, Frequency Hopping Spread Spectrum System, and Hybrid System Devices Operating Under Section 15.247 of the FCC Rules |

2.3. Calibration and Uncertainty

Measuring Instrument Calibration

In accordance with UKAS requirements all the measurement equipment is on a calibration schedule. All equipment was within the calibration period on the date of testing.

Measurement Uncertainty

No measurement or test can ever be perfect and the imperfections give rise to error of measurement in the results. Consequently the result of a measurement is only an approximation to the value measured (the specific quantity subject to measurement) and is only complete when accompanied by a statement of the uncertainty of the approximation.

The expression of uncertainty of a measurement result allows realistic comparison of results with reference values and limits given in specifications and standards.

The uncertainty of the result may need to be taken into account when interpreting the measurement results.

The reported expanded uncertainties below are based on a standard uncertainty multiplied by an appropriate coverage factor such that a confidence level of approximately 95% is maintained. For the purposes of this document “approximately” is interpreted as meaning “effectively” or “for most practical purposes”.

| Measurement Type | Range | Confidence Level (%) | Calculated Uncertainty |
|-------------------------------------|-----------------------|-----------------------------|-------------------------------|
| Duty Cycle | 2.4 GHz to 2.4835 GHz | 95% | ±1.14 % |
| 99% Occupied Bandwidth | 2.4 GHz to 2.4835 GHz | 95% | ±3.92 % |
| Minimum 6 dB Bandwidth | 2.4 GHz to 2.4835 GHz | 95% | ±4.59 % |
| Conducted Maximum Peak Output Power | 2.4 GHz to 2.4835 GHz | 95% | ±1.13 dB |
| Conducted Band Edge Emissions | 2.4 GHz to 2.4835 GHz | 95% | ±2.62 dB |

The methods used to calculate the above uncertainties are in line with those recommended within the various measurement specifications. Where measurement specifications do not include guidelines for the evaluation of measurement uncertainty the published guidance of the appropriate accreditation body is followed.

2.4. Test and Measurement Equipment

Test Equipment Used for Transmitter Conducted Tests

| Asset No. | Instrument | Manufacturer | Type No. | Serial No. | Date Calibration Due | Cal. Interval (Months) |
|------------------|-------------------------|---------------------|-----------------|-------------------|-----------------------------|-------------------------------|
| M2001 | Thermohygrometer | Testo | 608-H1 | 45041824 | 05 Jan 2021 | 12 |
| M1999 | RF Power Sensor | Dare Instruments | RPR3006W | 15I00041SN 079 | 28 May 2021 | 12 |
| A2525 | Attenuator | AtlanTecRF | AN18W5-10 | 832827 | Calibrated before use | - |
| M1835 | Signal Analyser | Rohde & Schwarz | FSV30 | 103050 | 14 Apr 2021 | 12 |
| G0614 | Signal Generator | Rohde & Schwarz | SMB100A | 177687 | 19 May 2023 | 36 |
| M1886 | Test Receiver | Rohde & Schwarz | ESU26 | 1000554 | 15 May 2021 | 12 |
| G0628 | Vector Signal generator | Rohde & Schwarz | SMBV100A | 261847 | 08 October 2023 | 36 |
| A2527 | Attenuator | AltanTechRF | AN18W5-20 | 832828#2 | Calibrated before use | - |

3. Equipment Under Test (EUT)

3.1. Identification of Equipment Under Test (EUT)

| | |
|--|-------------------------------------|
| Brand Name: | Raspberry Pi |
| Model Name or Number / PMN: | Raspberry Pi RM0 |
| Test Sample Serial Number: | 3185953 (<i>Conducted sample</i>) |
| Hardware Version: | V1.0 |
| Software Version: | V1.0 |
| FCC ID: | 2ABCB-RPIRM0 |
| ISED Canada Certification Number: | IC: 20953-RPIRM0 |

3.2. Modifications Incorporated in the EUT

No modifications were applied to the EUT during testing.

3.3. Additional Information Related to Testing

| | | | |
|--|---|-----------------------|--------------------------------|
| Technology Tested: | <i>Bluetooth</i> Low Energy (Digital Transmission System) | | |
| Type of Unit: | Transceiver | | |
| Channel Spacing: | 2 MHz | | |
| Modulation: | GFSK | | |
| Data Rate: | 1 Mbps | | |
| Power Supply Requirement(s): | Nominal | 5.0 VDC | |
| Maximum Conducted Output Power: | 4.7 dBm | | |
| Transmit Frequency Range: | 2402 MHz to 2480 MHz | | |
| Transmit Channels Tested: | Channel ID | Channel Number | Channel Frequency (MHz) |
| | Bottom | 37 | 2402 |
| | Middle | 17 | 2440 |
| | Top | 39 | 2480 |

3.4. Description of Available Antennas

The table below lists the internal niche antenna and the external antenna available.

| Manufacturer | Type | Frequency Range (MHz) | Antenna Gain (dBi) |
|---------------------|-------------|------------------------------|---------------------------|
| ProAnt | Internal | 2400 to 2480 | 3.5 |
| Raspberry Pi | External | 2400 to 2480 | 2.0 |

3.5. Description of Test Setup

Support Equipment

The following support equipment was used to exercise the EUT during testing:

| | |
|------------------------------|----------------------------|
| Description: | Pi4 board used as test jig |
| Brand Name: | Raspberry Pi4 |
| Model Name or Number: | Pi4 |
| Serial Number: | 10000000ae5754eo |

| | |
|------------------------------|-----------------------------|
| Description: | Micro SD Card with OS image |
| Brand Name: | SanDisk |
| Model Name or Number: | 16 GB card |
| Serial Number: | Not marked or stated |

| | |
|------------------------------|----------------------|
| Description: | USB Mouse |
| Brand Name: | Microsoft |
| Model Name or Number: | 1113 |
| Serial Number: | Not marked or stated |

| | |
|------------------------------|----------------------|
| Description: | USB Keyboard |
| Brand Name: | Dell |
| Model Name or Number: | KB212-B |
| Serial Number: | Not marked or stated |

| | |
|------------------------------|--|
| Description: | Power Supply. 100-230 VAC Input / 5 VDC Output |
| Brand Name: | Raspberry Pi4 |
| Model Name or Number: | KSA-15E-051300HK |
| Serial Number: | Not marked or stated |

| | |
|------------------------------|----------------------|
| Description: | USB Mouse |
| Brand Name: | Raspberry Pi |
| Model Name or Number: | RPI-MOUSE |
| Serial Number: | Not marked or stated |

| | |
|------------------------------|----------------------|
| Description: | USB Keyboard |
| Brand Name: | HP |
| Model Name or Number: | KU-0316 |
| Serial Number: | Not marked or stated |

Support Equipment (continued)

| | |
|------------------------------|--------------|
| Description: | Monitor |
| Brand Name: | ASUS |
| Model Name or Number: | PA238 |
| Serial Number: | D9LMTF114809 |

Operating Modes

The EUT was tested in the following operating mode(s):

- Transmitting at maximum power in *Bluetooth* LE mode with modulation, maximum possible data length available and Pseudorandom Bit Sequence 9.

Configuration and Peripherals

The EUT was tested in the following configuration(s):

- The Pi4 test jig was used to run *Bluetooth* LE test commands on the EUT. The Pi4 test jig was used to enable continuous transmission and to select the test channels and packet types as required.
- The EUT was powered via the Pi4 test jig which was powered from an AC/DC switch mode power supply.

Test Setup Diagrams

Conducted Tests:

Test Setup for Transmitter Conducted Tests

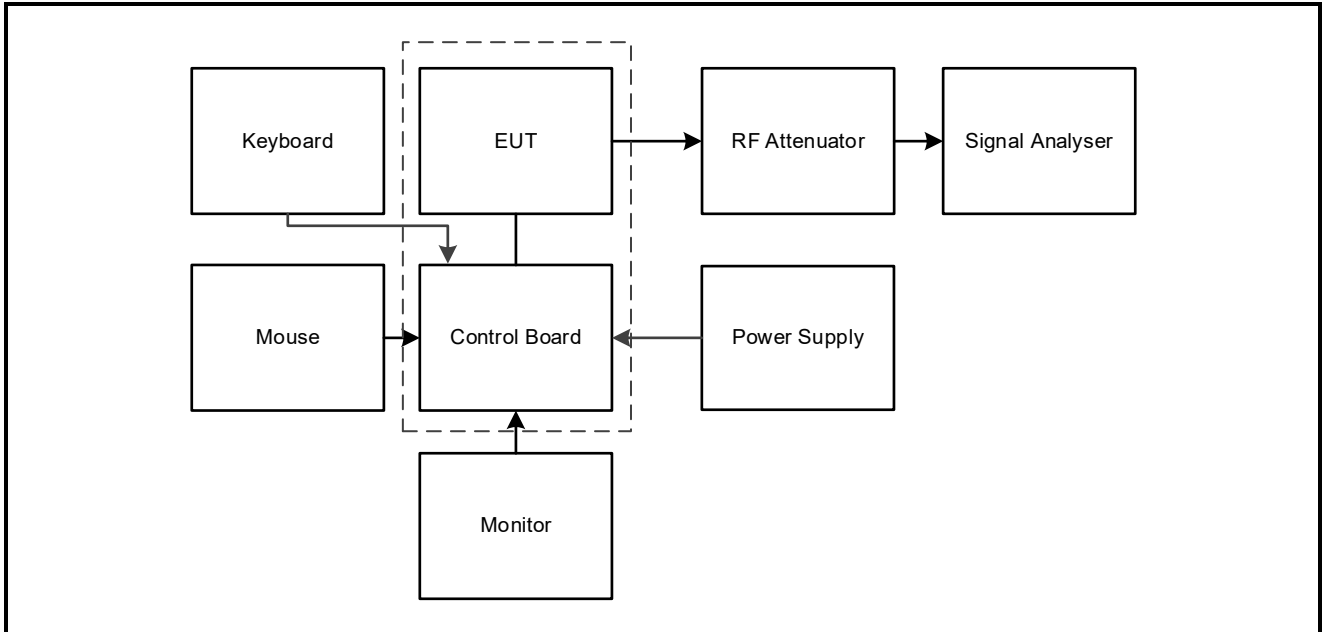

4. Antenna Port Test Results

4.1. Transmitter Duty Cycle

Test Summary:

| | | | |
|-----------------------------------|--------------------------------|-------------------|--------------|
| Test Engineers: | Matthew Botfield & Jose Bayona | Test Date: | 28 July 2020 |
| Test Sample Serial Number: | 3185953 | | |

| | |
|-------------------------------|---|
| FCC Reference: | Part 15.35(c) |
| ISED Canada Reference: | RSS-Gen 8.2 |
| Test Method Used: | FCC KDB 558074 Section 6 referencing ANSI C63.10 Section 11.6 |

Environmental Conditions:

| | |
|-------------------------------|----|
| Temperature (°C): | 23 |
| Relative Humidity (%): | 52 |

Note(s):

- In order to assist with the determination of the average level of spurious emissions field strength in LE mode, measurements were made of duty cycle to determine the transmission duration and the silent period time of the transmitter. The transmitter duty cycle was measured using a spectrum/signal analyser in the time domain and calculated by using the following calculation:

$$10 \log (1 / (\text{On Time} / [\text{Period or } 100 \text{ ms whichever is the lesser}])).$$

Results:

| Pulse Duration (µs) | Period (µs) | Duty Cycle (dB) |
|---------------------|-------------|-----------------|
| 385.563 | 625.063 | 2.1 |

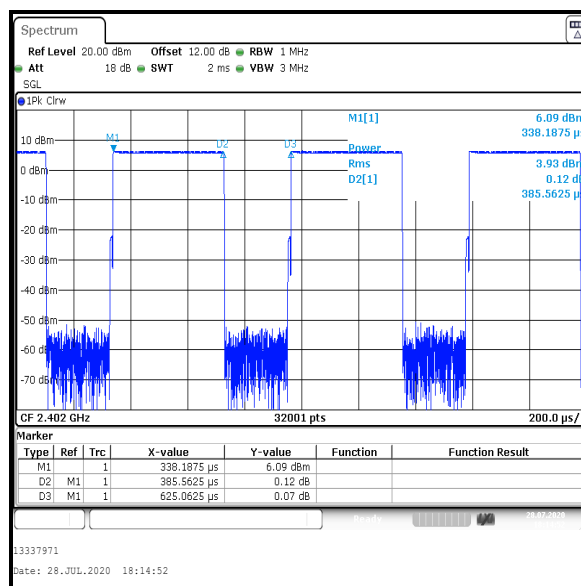

4.2. Transmitter 99% Occupied Bandwidth

Test Summary:

| | | | |
|-----------------------------------|-----------------------------------|-------------------|--------------|
| Test Engineers: | Matthew Botfield & Jose Bayona | Test Date: | 28 July 2020 |
| Test Sample Serial Number: | 3185953 | | |

| | |
|-------------------------------|-----------------------------|
| FCC Reference: | N/A |
| ISED Canada Reference: | RSS-Gen 6.7 |
| Test Method Used: | RSS-Gen 6.7 and Notes below |

Environmental Conditions:

| | |
|-------------------------------|----|
| Temperature (°C): | 23 |
| Relative Humidity (%): | 52 |

Note(s):

1. The 99% emission bandwidth was measured using the signal analyser occupied bandwidth function. The resolution bandwidth was set in the range of 1% to 5% of the occupied bandwidth and the video bandwidth set to 3 times the resolution bandwidth. The span was set to capture all products of the modulation process including emission skirts.
2. The signal analyser resolution bandwidth was set to 30 kHz and video bandwidth 100 kHz. A peak detector was used, sweep time was set to auto and the trace mode was Max Hold. The span was set to 5 MHz. The signal analyser function set the measurements to be made at 99% of the emission bandwidth. The results are given in the tables below.
3. The signal analyser was connected to the RF port on the EUT using suitable attenuation and RF cable.

Transmitter 99% Occupied Bandwidth (continued)

Results:

| Channel | 99% Occupied Bandwidth (kHz) |
|---------|------------------------------|
| Bottom | 1056.440 |
| Middle | 1049.204 |
| Top | 1049.204 |

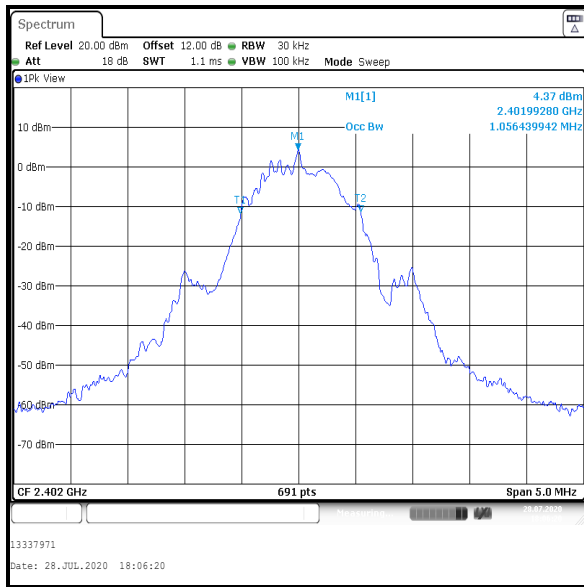

Bottom Channel

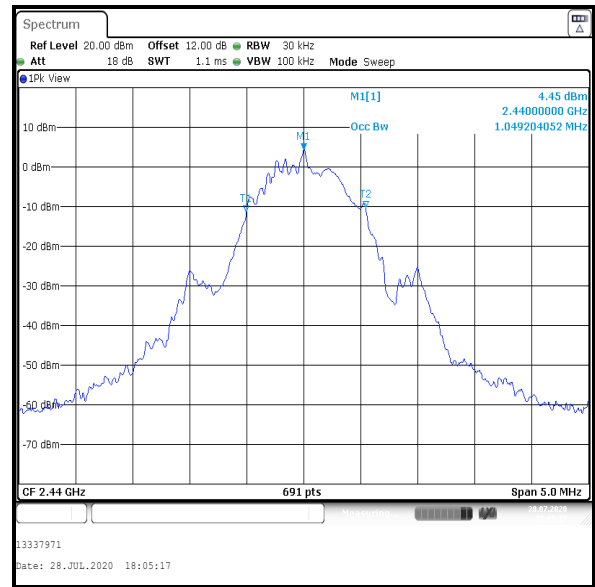

Middle Channel

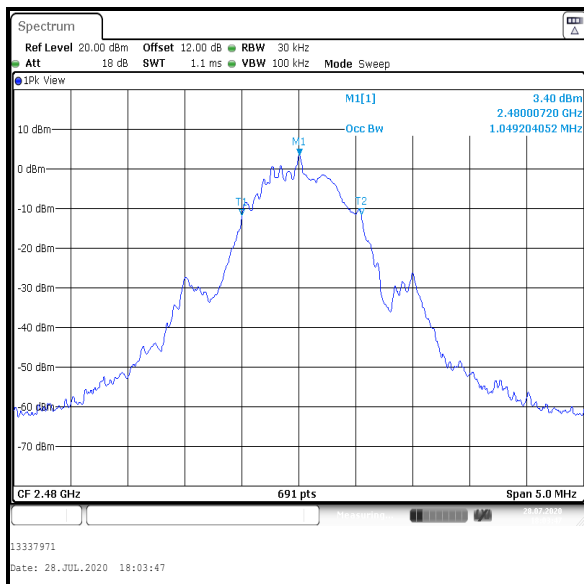

Top Channel

4.3. Transmitter Minimum 6 dB Bandwidth

Test Summary:

| | | | |
|-----------------------------------|-----------------------------------|-------------------|--------------|
| Test Engineers: | Matthew Botfield & Jose Bayona | Test Date: | 28 July 2020 |
| Test Sample Serial Number: | 3185953 | | |

| | |
|-------------------------------|---|
| FCC Reference: | Part 15.247(a)(2) |
| ISED Canada Reference: | RSS-Gen 6.7 / RSS-247 5.2(a) |
| Test Method Used: | FCC KDB 558074 Section 8.2 referencing ANSI C63.10 Section 11.8.1 |

Environmental Conditions:

| | |
|-------------------------------|----|
| Temperature (°C): | 23 |
| Relative Humidity (%): | 52 |

Note(s):

1. 6 dB DTS bandwidth tests were performed using a signal analyser in accordance with ANSI C63.10 Section 11.8.1 Option 1 measurement procedure. The signal analyser resolution bandwidth was set to 100 kHz and video bandwidth 300 kHz. A peak detector was used, sweep time was set to auto and the trace mode was Max Hold. The DTS bandwidth was measured at 6 dB down from the peak of the signal.
2. The signal analyser was connected to the RF port on the EUT using suitable attenuation and RF cable.

Transmitter Minimum 6 dB Bandwidth (continued)

Results:

| Channel | 6 dB Bandwidth (kHz) | Limit (kHz) | Margin (kHz) | Result |
|---------|----------------------|-------------|--------------|----------|
| Bottom | 723.600 | ≥500 | 223.600 | Complied |
| Middle | 716.400 | ≥500 | 216.400 | Complied |
| Top | 723.600 | ≥500 | 223.600 | Complied |

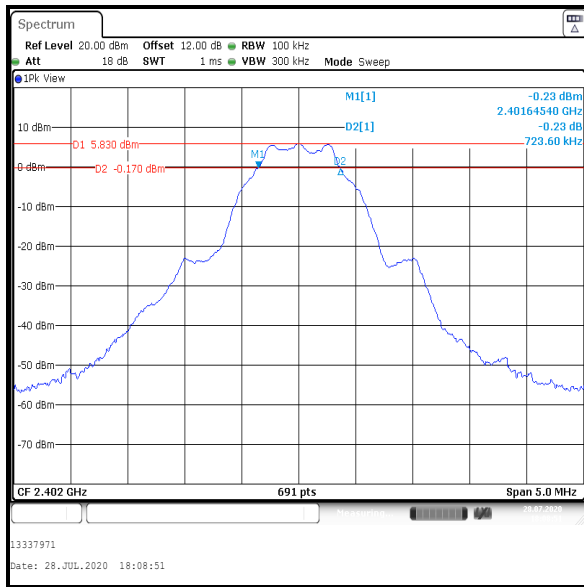

Bottom Channel

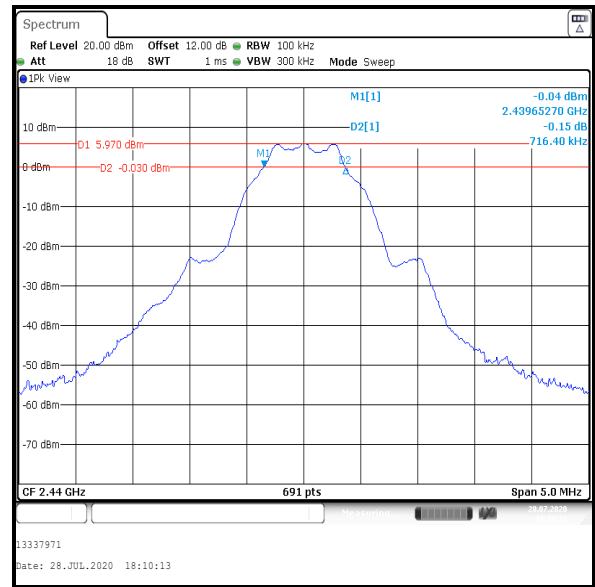

Middle Channel

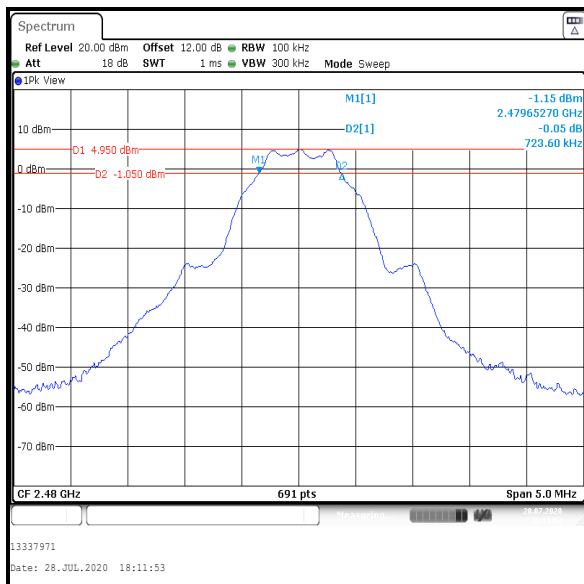

Top Channel

4.4. Transmitter Maximum Peak Output Power

Test Summary:

| | | | |
|-----------------------------------|------------------|-------------------|-------------------|
| Test Engineer: | Matthew Botfield | Test Date: | 07 September 2020 |
| Test Sample Serial Number: | 3185953 | | |

| | |
|-------------------------------|---|
| FCC Reference: | Part 15.247(b)(3) |
| ISED Canada Reference: | RSS-Gen 6.12 / RSS-247 5.4(d) |
| Test Method Used: | FCC KDB 558074 Section 8.3.1.1 referencing ANSI C63.10 Section 11.9.1.1 and Notes below |

Environmental Conditions:

| | |
|-------------------------------|----|
| Temperature (°C): | 22 |
| Relative Humidity (%): | 56 |

Note(s):

1. Conducted power tests were performed using a signal analyser in accordance with ANSI C63.10 Section 11.9.1.1 with the RBW \geq DTS bandwidth procedure.
2. The signal analyser resolution bandwidth was set to 1 MHz and video bandwidth of 3 MHz. A peak detector was used, sweep time was set to auto and trace mode was Max Hold. The span was set to 3 MHz. A marker was placed at the peak of the signal and the results recorded in the tables below.
3. The signal analyser was connected to the RF port on the EUT using suitable attenuation and RF cable. An RF level offset was entered on the signal analyser to compensate for the loss of the attenuator and RF cable.
4. The conducted power was added to the highest declared antenna gain to obtain the EIRP.

Results:

| Channel | Conducted Peak Power (dBm) | Conducted Peak Power Limit (dBm) | Margin (dB) | Result |
|---------|----------------------------|----------------------------------|-------------|----------|
| Bottom | 4.6 | 30.0 | 25.4 | Complied |
| Middle | 4.7 | 30.0 | 25.3 | Complied |
| Top | 4.2 | 30.0 | 25.8 | Complied |

| Channel | Conducted Peak Power (dBm) | Highest Declared Antenna Gain (dBi) | EIRP (dBm) | De Facto EIRP Limit (dBm) | Margin (dB) | Result |
|---------|----------------------------|-------------------------------------|------------|---------------------------|-------------|----------|
| Bottom | 4.6 | 3.5 | 8.1 | 36.0 | 27.9 | Complied |
| Middle | 4.7 | 3.5 | 8.2 | 36.0 | 27.8 | Complied |
| Top | 4.2 | 3.5 | 7.7 | 36.0 | 28.3 | Complied |

Transmitter Maximum Peak Output Power (continued)

Results:

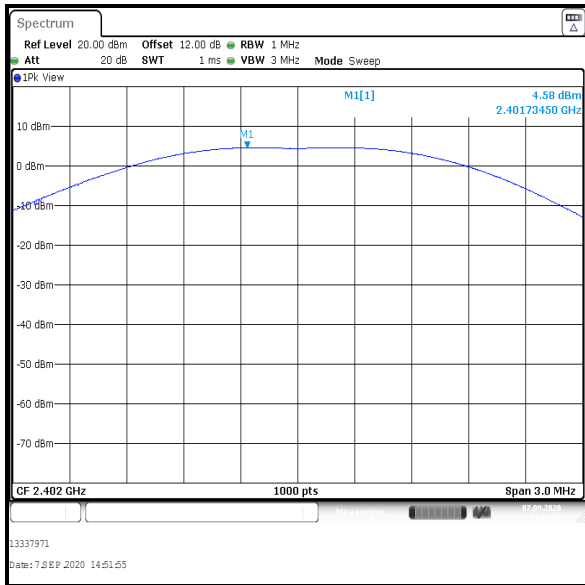

Bottom Channel

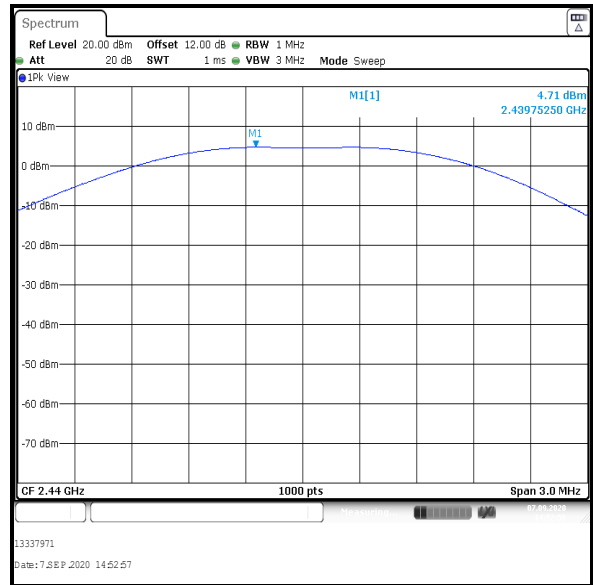

Middle Channel

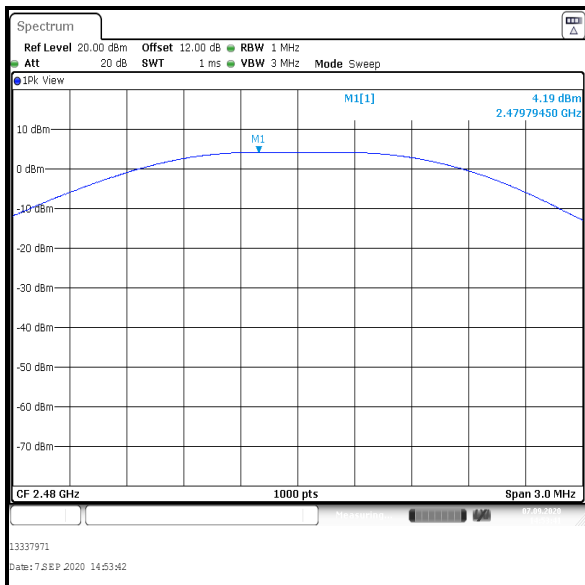

Top Channel

4.5. Transmitter Band Edge Conducted Emissions

Test Summary:

| | | | |
|-----------------------------------|------------------|-------------------|-----------------|
| Test Engineer: | Matthew Botfield | Test Date: | 28 October 2020 |
| Test Sample Serial Number: | 3185953 | | |

| | |
|-------------------------------|--|
| FCC Reference: | Part 15.247(d) |
| ISED Canada Reference: | RSS-Gen 6.13, 8.9 & 8.10 / RSS-247 5.5 |
| Test Method Used: | KDB 558074 Section 8.7 referencing ANSI C63.10 Section 11.11, 11.12 & 11.13 |

Environmental Conditions:

| | |
|-------------------------------|----|
| Temperature (°C): | 21 |
| Relative Humidity (%): | 48 |

Note(s):

1. The EUT was set to transmit on the bottom channel when performing measurements at the lower band edge.
2. Upper band edge and lower restricted band results are contained within test report R13337971-E5 / E6.
3. As the band edges fall within non-restricted bands, only peak measurements are required. In accordance with FCC KDB 558074 Section 11.1, the test method in Section 11.3 was followed: the test receiver resolution bandwidth was set to 100 kHz and video bandwidth 300 kHz. A peak detector was used, sweep time was set to auto and trace mode was Max Hold. The test receiver was left to sweep for a sufficient length of time in order to maximise the carrier level and out-of-band emissions. A marker and corresponding reference level line were placed on the peak of the carrier. As the maximum peak conducted output power was measured using a peak detector in accordance with FCC KDB 558074 Section 9.1.1 an out-of-band limit line was placed 20 dB below the peak level (FCC KDB 558074 Section 11.1(a)). A marker was placed on the band edge spot frequencies and a second marker placed on the highest emission level in the adjacent non-restricted band of operation (where a higher level emission was present). Marker frequencies and levels were recorded.

Transmitter Band Edge Conducted Emissions (continued)

Results:

| Frequency (MHz) | Level (dBm) | -20 dBc Limit (dBm) | Margin (dB) | Result |
|-----------------|-------------|---------------------|-------------|----------|
| 2391.346 | -45.7 | -12.1 | 33.6 | Complied |
| 2400.000 | -47.4 | -12.1 | 35.3 | Complied |

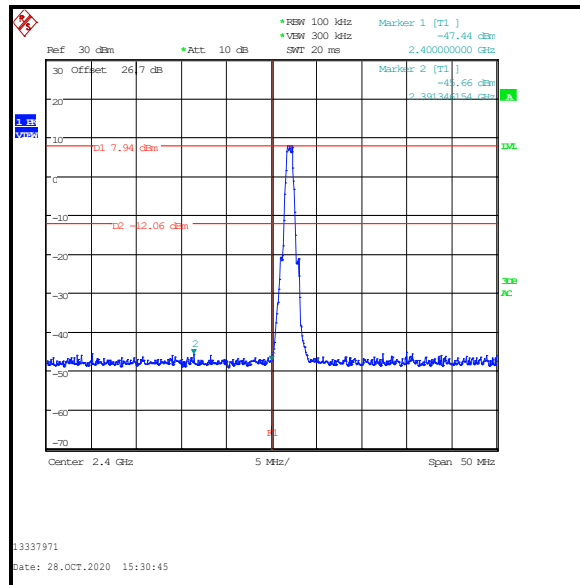

Lower Band Edge

--- END OF REPORT ---